

# OW1 OVERWATER RAMS

## TECHNICAL DETAILS



Rig Weight	0.7 T
Maximum Operating Ram Capacity	18 T
Length	1.30 m
Width	0.40 m
Height	2.50 m
Noise Output at 2 m	88 dBA
Clamp Arrangement	36/55mm Push Pull Clamp
Ram Stroke	1.35 m
Maximum Casing Size	55 mm

This robust, powerful unit is ideal for marine CPTs, sampling and instrumentation installation.

They are self-contained and supplied with a hydraulic power pack, generator and data logging system.

The rams can be mounted or bolted to the platform, or even integrated into the drilling masts to perform CPTs within boreholes to allow fast and effective testing between setting riser casings and drill-outs.

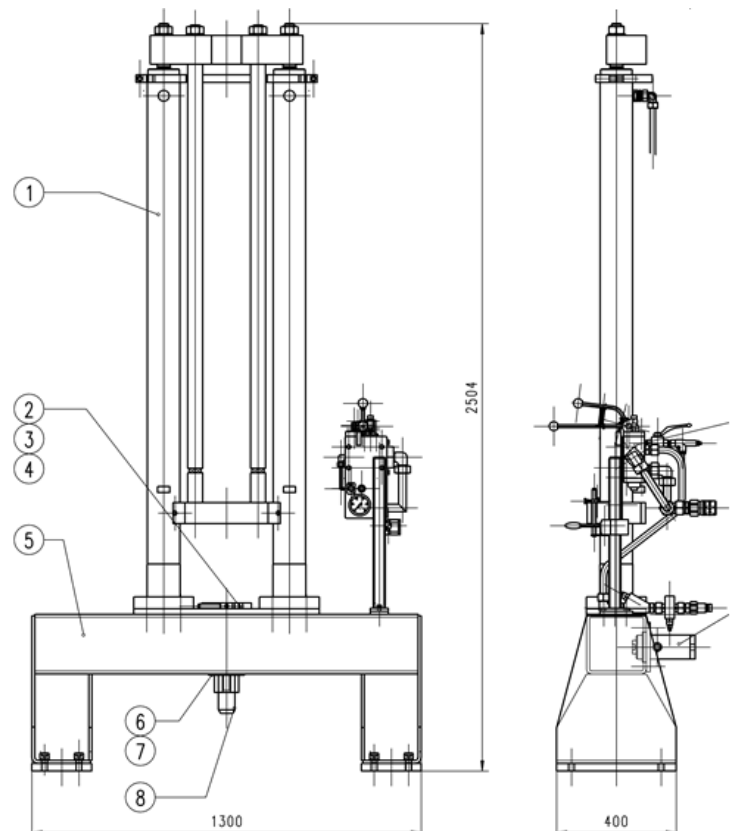

[www.lankelma.com](http://www.lankelma.com)

Tel: +44 (0)1797 280050

Fax: +44 (0)1797 280195

Email: [info@lankelma.com](mailto:info@lankelma.com)

Lankelma Limited, Cold Harbour Barn, Cold Harbour Lane, Iden, East Sussex. TN31 7UT